

TM50/PRO INSTALLATION MANUAL.

The TM50 & TM50 pro encoder motors have been developed for the SurRon Ultra Bee and the Torp Controllers with the possibility of being paired with other controller brands. If used with other controller brands, contact those controller manufacturers if you need help with setting it up.

IN THE PACKAGE YOU WILL RECEIVE FOLLOWING ITEMS FOR:

SHAFT (PULLEY) SIDE

1pc: M8x50mm bolt

1pc: M8x55mm bolt

FRONT SIDE

1pc: M8x20mm bolt

1pc: M8x25mm bolt

For successful installation, please follow the pulley installation steps and mounting instructions you can find in the manual below.

How to use it with Torp Controllers: Once the motor is installed on the bike and connected to the Torp Controller, connect to the Torp App. Visit the 5th screen of the Torp App and navigate to the CALIBRATION. Start the SETUP WIZARD and select the TM50 or TM50 Pro from the options presented. Follow the calibration wizard so everything is set up correctly.

INSTRUCTIONS FOR PULLEY INSTALLATION

This is the first step before mounting the TM50/PRO motor on your bike.



1. Uninstall the stock motor.

2.



Remove this nut.

3.



Remove the pulley with a lever, working a little from each side.

4.



Remove the nut from the TORP motor.



5.

Mount the pulley on the shaft. The shaft key should be pre-mounted on the shaft.

Tighten the nut slightly in clockwise direction.

TM50/PRO MOUNTING INSTRUCTIONS

1.

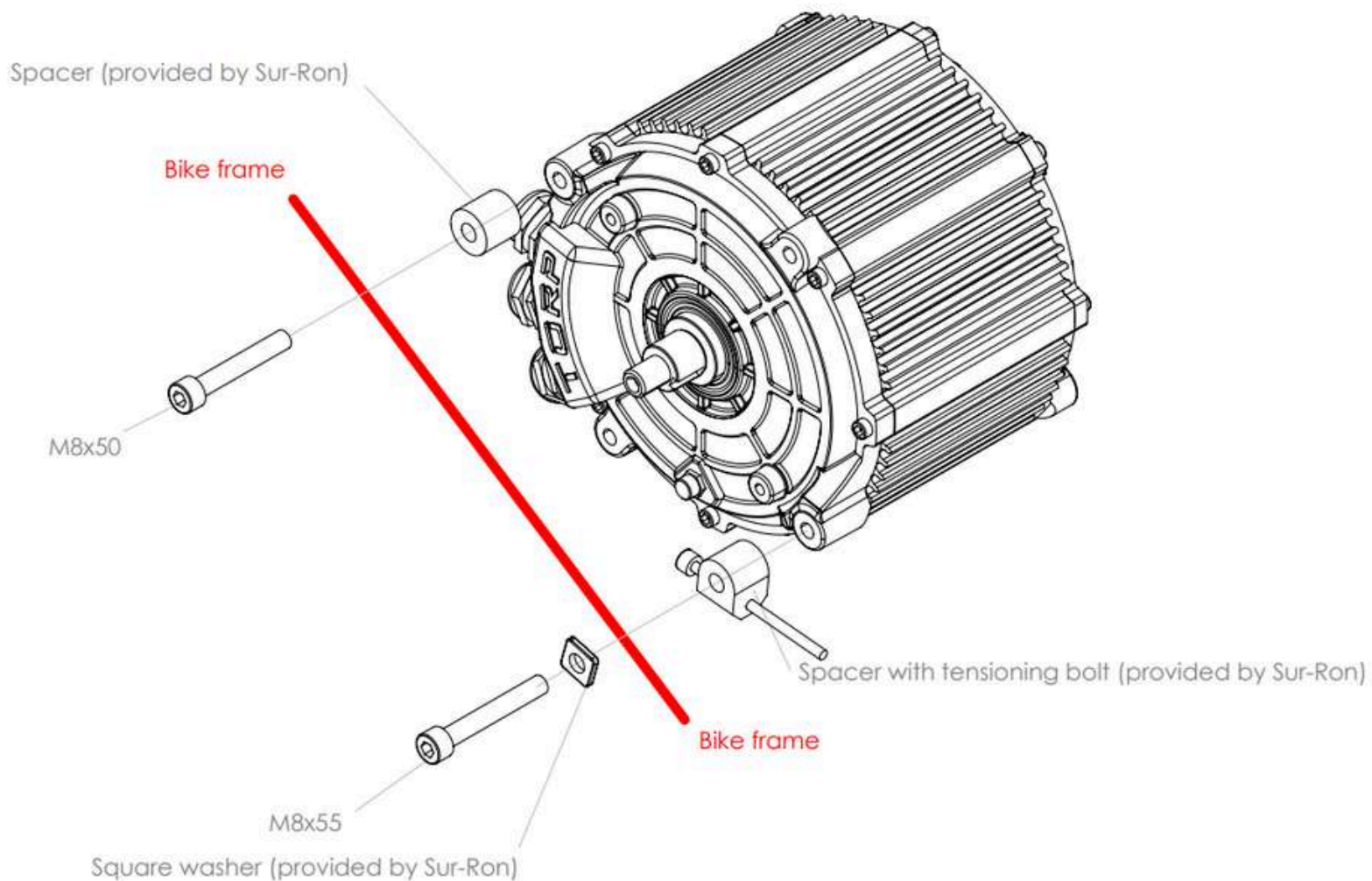

2.

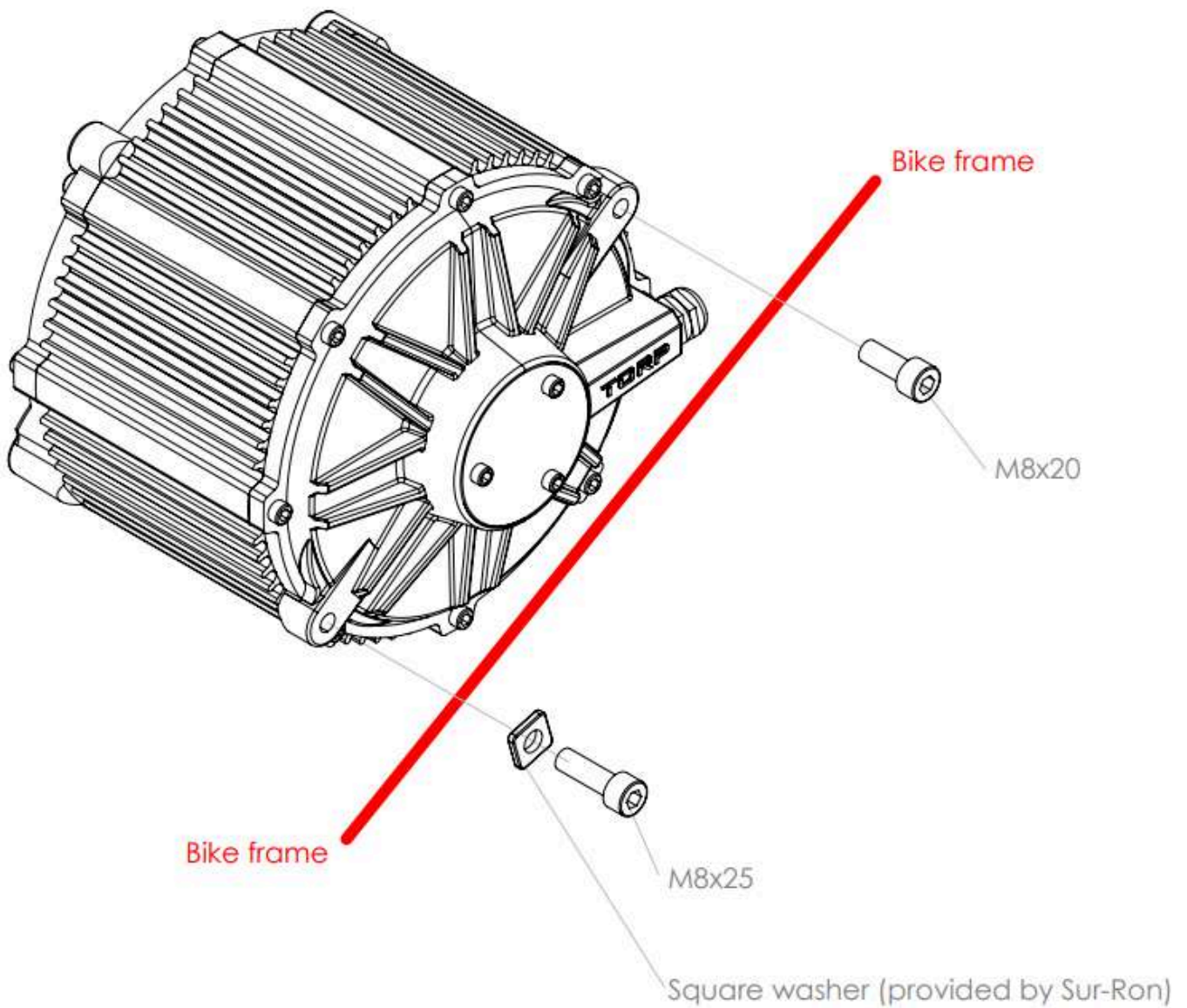

3.



When everything is mounted, press the rear brake and tighten the nut (clockwise direction) a bit more to 40-50 Nm.